

ROTARY VANE VACUUM PUMPS & SYSTEMS

DuraVane®



◀ **DuraVane**
212 CFM stack-mounted triplex
system for medical applications

DuraVane ▶
Rotary vane vacuum
pump systems available
in a large variety
of configurations



DuraVane ▶
lubricated rotary
vane vacuum pumps



◀ **DuraVane^{HV}**
high vacuum lubricated
rotary vane vacuum pumps



DuraVane ▶
oil-free (dry) rotary
vane vacuum pumps



DEKKER
VACUUM TECHNOLOGIES, INC.

dekkervacuum.com

The Experts in Vacuum Solutions

888.925.5444

DEKKER VACUUM TECHNOLOGIES, INC. ISO 9001 2015 CERTIFIED

DuraVane® LUBRICATED rotary vane vacuum pumps

Performance characteristics rotary vane vacuum pumps											
Rotary Vane Vacuum Pumps	Nominal Capacity (ACFM)	Motor Size (HP/kW)				Max Vacuum Level (Torr)	Pump Speed (RPM)		Noise (at 3 ft) (dBA)	Weight bare-shaft	
		50 Hz		60 Hz			50Hz	60Hz		Kg	Lbs
		HP	kW	HP	kW						
Lubricated Pumps											
RVL003H	2.6	0.2	0.15	0.2	0.15	1.5	2900	3500	60	5.5	12
RVL006H	5.6	0.4	0.3	0.4	0.3	1.5	2900	3500	60	10	22
RVL010H	8.5	0.75	0.55	0.75	0.55	1.5	2900	3500	62	16	35
RVL014H	14.1	1	0.75	1.25	0.93	1.5	2900	3500	67	19	42
RVL020H	19	1	0.75	1.25	0.92	0.5	1450	1750	65	25	55
RVL031H	28	1.5	1.1	2	1.5	0.1	1450	1750	66	47	102
RVL051H	45	2	1.5	3	2.2	0.1	1450	1750	68	45	98
RVL076H	75	3	2.2	4	3	0.1	1450	1750	68	70	155
RVL111H	106	4	3	5	3.7	0.1	1450	1750	70	80	176
RVL145HH	145	5.5	4	7.5	5.5	0.4	1450	1750	74	155	340
RVL212HH	212	7.5	5.5	10	7.5	0.4	1450	1750	76	164	361
RVL301HH	280	10	7.5	15	11	0.4	1450	1750	79	336	740
RVL301LH	280	10	7.5	15	11	7.5	1450	1750	79	336	740
RVL401HH	375	15	11	20	15	0.4	1450	1750	80	359	790
RVL401LH	375	15	11	20	15	7.5	1450	1750	80	359	790
RVL475HH	465	20	15	25	18.5	0.075	980	1170	79	725	1600
RVL475LH	465	20	15	25	18.5	0.375	980	1170	79	725	1600
RVL700HH	710	30	22	40	30	0.5	980	1170	81	955	2100
RVL700LH	710	30	22	40	30	15	980	1170	81	955	2100
Lubricated pumps for saturated air (wet) service											
RVL020W	19	1	0.75	1.25	0.92	1.5	1450	1750	65	25	56
RVL031W	28	1.5	1.1	2	1.5	1.5	1450	1750	66	42	93
RVL051W	45	2	1.5	3	2.2	1.5	1450	1750	68	44	97
RVL076W	75	3	2.2	4	3	1.5	1450	1750	68	71	157

... Well-designed, reliable and economically priced

DuraVane lubricated rotary vane vacuum pumps: single-stage pumps with an integrated oil-recirculation system, used in a variety of industries such as vacuum packing, lifting, chucking, paper converting, electronics, printing, biotech, laboratories and hospitals.

DuraVane lubricated rotary vane vacuum pumps for saturated air (wet) service are specifically developed for applications with high inlet water vapor content such as stone and glass cutting.



DESIGN FEATURES

- Heavy-duty construction
- Compact design, small footprint
- High-tech vane material provides long vane life
- Gas ballast valve is standard on most models
- Low noise level
- Low maintenance
- Air-cooled design is standard
- Internally mounted inlet check valve
- High efficiency multi-stage exhaust filter removes 99.9% of exhaust smoke
- Direct drive with flange-mounted motor
- Simple to install

Performance curves **DuraVane** lubricated rotary vane pumps
Based on 29.92" Hg barometric pressure, inlet temperature 70°F.

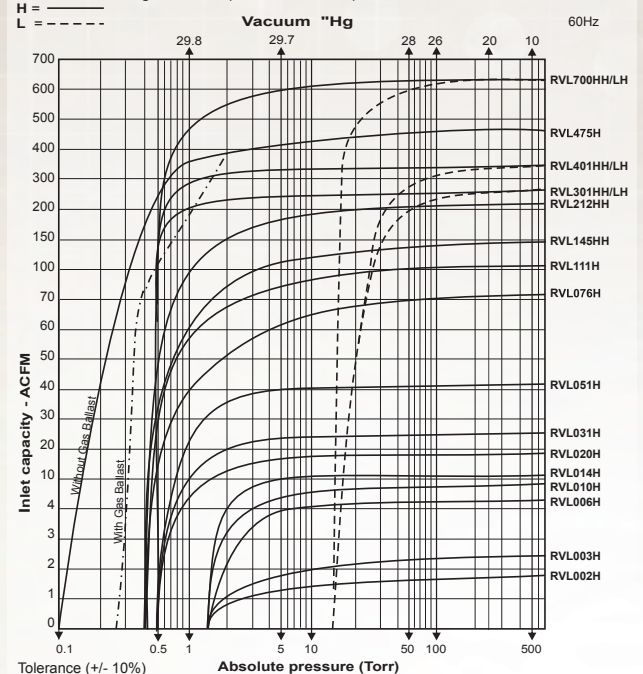

▶ DEKKER offers a complete range of accessories and carries a comprehensive inventory of pumps and parts. For emergency repairs, DEKKER takes pride in offering same-day shipping of most standard parts. DEKKER maintains an extensive domestic and global network of authorized service centers.

DuraVane® OIL-FREE (DRY) rotary vane vacuum pumps

Performance characteristics rotary vane vacuum pumps

Rotary Vane Vacuum Pumps	Nominal Capacity (ACFM)	Motor Size (HP/kW)				Max Vacuum Level (Torr)	Pump Speed (RPM)		Noise (at 3 ft) (dBA)	Weight bare-shaft	
		50 Hz		60 Hz			50Hz	60Hz		Kg	Lbs
		HP	kW	HP	kW						
Oil-free (dry) pumps											
RVD002L	2	0.25	0.18	0.25	0.18	90	2900	3500	62	5	11
RVD004L	4.2	0.4	0.3	0.4	0.3	90	2900	3500	62	8	18
RVD007L	7	0.6	0.44	0.6	0.44	90	1450	1750	65	15	34
RVD012L	12	0.75	0.55	1	0.75	90	1450	1750	65	30	65
RVD018L	18	1	0.75	1.25	0.92	90	1450	1750	68	30	65
RVD028L	28	2	1.5	2.5	1.85	90	1450	1750	72	40	88
RVD040L	42	2	1.5	3	2.2	90	1450	1750	72	71	156
RVD060L	56	3	2.2	4	3.7	90	1450	1750	74	74	162
RVD075L	71	4	3	5	3.7	90	1450	1750	77	93	205

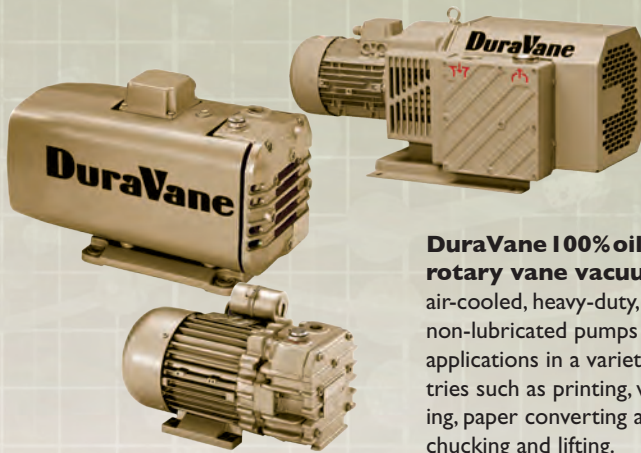

DuraVane 100% oil-free (dry) rotary vane vacuum pumps: air-cooled, heavy-duty, non-lubricated pumps for vacuum applications in a variety of industries such as printing, woodworking, paper converting and vacuum chucking and lifting.

...Exclusive design:
fewer vanes,
longer vane life

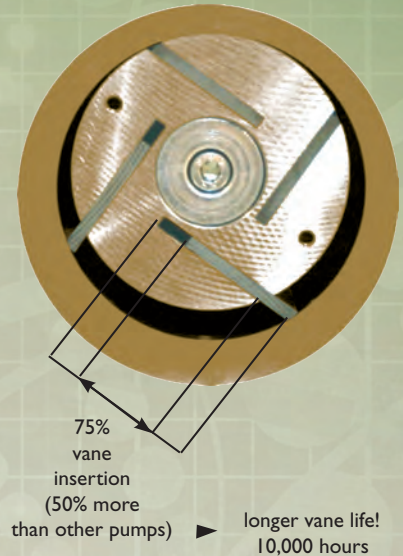

DESIGN FEATURES

- Fewer vanes than other oil-free rotary vane vacuum pumps
- High-tech, self-lubricating, long-life graphite composite vane material
- Longer vane life and less vane replacement, lower maintenance cost
- Built-in inlet filter for models of 1HP and higher
- Heavy-duty construction
- Direct drive
- Low noise level
- Air-cooled design
- Compact design

DuraVane oil-free (dry) rotary vane compressors are available in capacities from 2 – 95 CFM (0.2 – 10 HP), maximum pressure up to 15 psig. These are heavy-duty, motor-mounted units, extremely reliable for industrial applications.

Performance curves DuraVane oil-free (dry) rotary vane pumps

Based on 29.92" Hg barometric pressure, inlet temperature 70°F.

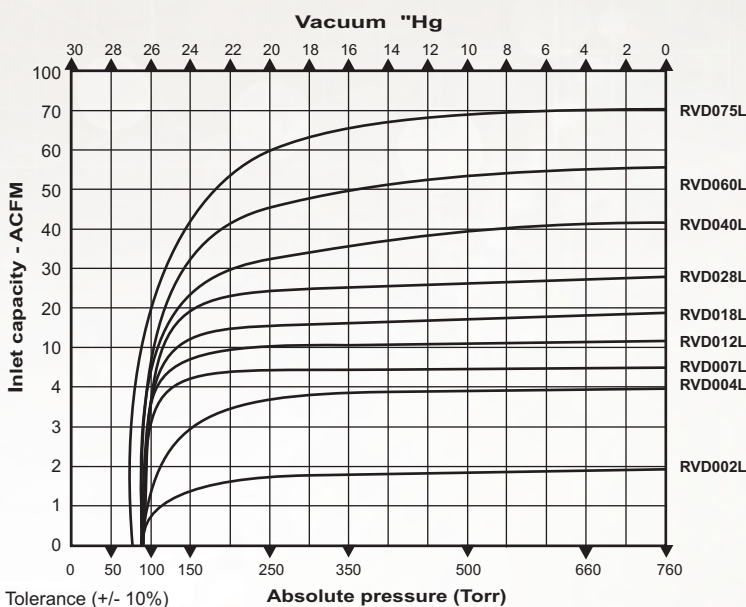

DuraVane[®] rotary vane vacuum pump SYSTEMS

... Well-designed, reliable and economically priced

Rotary vane vacuum pump systems are available in multiple configurations, such as stack-mounted, base-mounted or tank-mounted units.

DEKKER supplies NFPA 99 compliant medical packages for hospitals and laboratories as well as standard industrial packages in capacities ranging from 2.2-710 CFM per pump.

All multi-pump systems are equipped with a microprocessor, eliminating vacuum switches.

Applications engineers at DEKKER Vacuum Technologies offer expertise based on years of experience in the vacuum industry, and are available to answer any questions you may have.



DuraVane

Duplex vertical tank-mounted rotary vane vacuum pump system, NFPA 99 compliant for medical applications.



DuraVane

Duplex base-mounted NFPA 99 compliant rotary vane pump systems for medical applications.



DuraVane

Custom-engineered, rotary vane vacuum pump system for solvent recovery in pharmaceutical application.

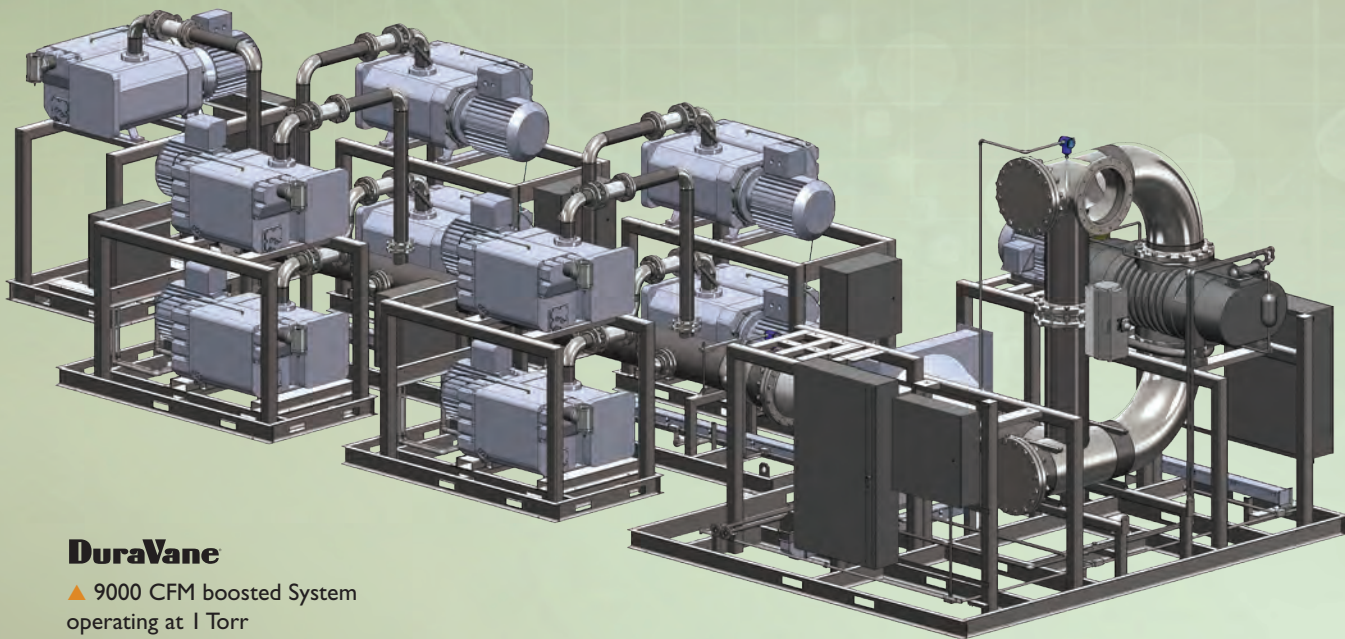

DuraVane

▲ 9000 CFM boosted System operating at 1 Torr

Data is subject to change without notice.

Call DEKKER: The Experts in Vacuum Solutions at 888-925-5444 for application expertise.

DuraVane^{HV} HIGH VACUUM rotary vane pumps

DuraVane^{HV} high vacuum rotary vane pumps are available in 6 models (RVR series) covering pumping speeds from 1.4 – 6 CFM and pressures down to 7.5×10^{-3} , 4 models (RVH series) covering pumping speeds from 2 – 12 CFM and ultimate blank-off pressure down to 3.8×10^{-3} Torr (total final pressures unless otherwise specified).

These units are specifically designed to provide reliability, higher ultimate vacuum, easy installation and operation as well as low maintenance.

Pumps are suitable for a variety of applications such as freeze drying, laboratory vacuum, distillation, TV tube and light bulb manufacturing, semiconductor industry, refrigeration, electronics, etc., where smaller pumps with higher ultimate vacuum are required.

...Excellent ultimate vacuum, easy installation, operation and low maintenance



DESIGN FEATURES

- Heavy-duty construction
- Compact design
- Multi-frequency motor
- Gas balast standard
- Low noise level
- Low maintenance
- Air-cooled design
- Direct drive
- Simple to install

Performance characteristics high vacuum rotary vane pumps

DuraVane ^{HV} System Model Number	Nominal Capacity (ACFM)	Motor Size 60Hz (HP)	Max Vacuum Level (Torr)	Partial final pressure (McLeod) (Torr)	Total final pressure with gas ballast (Torr)	Pump Speed (RPM)	Noise (at 3ft) (dBA)	Weight (Lbs)
DuraVaneHV high vacuum rotary vane pumps down to 7.5×10^{-3} Torr*								
RVR002M	2	0.25	7.5×10^{-1}	3.8×10^{-1}	1.5	3500	64	12
RVR002H	1.4	0.25	7.5×10^{-2}	3.8×10^{-2}	2.3	3500	64	14
RVR003M	3	0.5	7.5×10^{-2}	3.8×10^{-2}	2.3	1750	54	24
RVR003H	3	0.5	7.5×10^{-3}	3.8×10^{-3}	1.5×10^{-1}	1750	54	27
RVR006M	6	0.5	7.5×10^{-2}	3.8×10^{-2}	2.3	1750	54	28
RVR006H	6	0.5	7.5×10^{-3}	3.8×10^{-3}	1.5×10^{-1}	1750	54	30
DuraVaneHV high vacuum rotary vane pumps down to 3.8×10^{-3} Torr*								
RVH002H	2	0.5	3.8×10^{-3}	3.8×10^{-4}	1.5×10^{-1}	1750	54	22
RVH004H	3.8	1.25	3.8×10^{-3}	3.8×10^{-4}	2×10^{-1}	1750	54	51
RVH006H	6	1.25	3.8×10^{-3}	3.8×10^{-4}	1.5×10^{-1}	1750	54	53
RVH012H	12	1.25	3.8×10^{-3}	3.8×10^{-4}	6×10^{-2}	1750	54	58

* = Total final pressure unless otherwise specified.

Performance curves DEKKER DuraVane^{HV} high vacuum rotary vane pumps down to 7.5×10^{-3} Torr.

Based on 760 mm Hg (Torr) barometric pressure, inlet temperature 70°F. --- with gas ballast

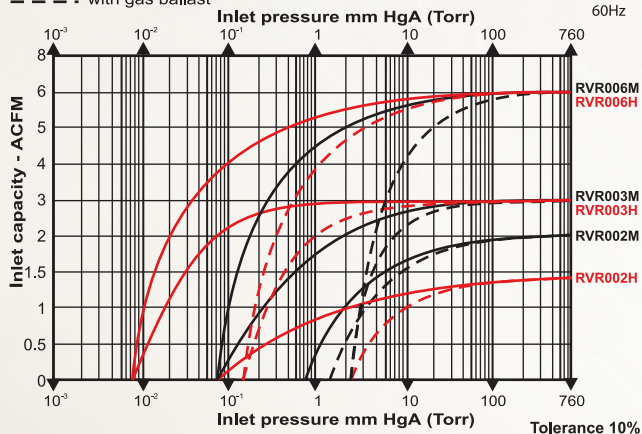

Performance curves DuraVane^{HV} high vacuum rotary vane pumps down to 3.8×10^{-3} Torr.

Based on 760 mm Hg (Torr) barometric pressure, inlet temperature 70°F. --- with gas ballast

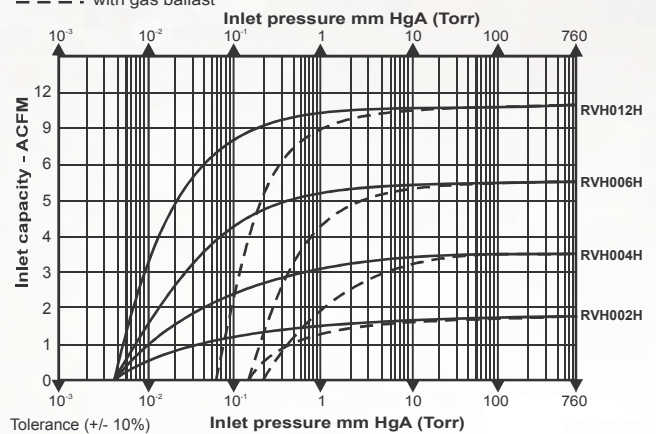



Process Savings



Energy Savings



Environmental Sustainability



Optimized Performance



Knowledge Base

TITAN[®]

Single and Two Stage Liquid Ring Vacuum Pumps
6-2,000 CFM

MAXIMA-C[™]

Large Capacity Conical Liquid Ring Vacuum Pumps
1,000 to 22,000 CFM

MAXIMA-K[™]

Large Capacity Liquid Ring Vacuum Pumps
1,500 to 39,000 CFM



Oil Sealed Liquid Ring Vacuum Pump Systems
35-5,400 CFM

DuraVane[®]

Lubricated and Dry Rotary Vane Vacuum Pumps
2-710 CFM

HullVac[™]

Rotary Piston Vacuum Pumps
17-1,280 CFM

ChemSeal[™]

Vacuum Pump Systems
15-10,000 CFM

AquaSeal[™]

Water Sealed Vacuum Pump Systems
15-39,000 CFM

AquaSeal[™] POWERGEN[®]

Vacuum Pump Systems
15-5,000 CFM



Collaborative Engineering from Start-To-Finish

DISTRIBUTED BY

INCREASE YOUR INDUSTRIAL VACUUM KNOWLEDGE

dekkervacuum.com



DKR_DURAVANE_06/2019_REV.5

GOLD STANDARD SUPPORT

Your Knowledge-Backed Guarantee. Need help sizing a vacuum pump? Having application problems? With over 100 years of combined experience, we've made it our business to know your needs as well as our systems capabilities. With DEKKER, you get a team of vacuum experts dedicated to helping you resolve system challenges, streamline processes, and optimize results.

Maintenance, service and repair so you keep operating at maximum efficiency.



888.925.5444 | dekkervacuum.com